

SUBMERSIBLE VORTEX PUMPS

**Model Numbers: D150V, DT15V, DT22V,
DT37V, DT55V & DT75V**

DEPEND ON
DAVEY

WATER PRODUCTS

SUMP PUMPS

PRODUCT DESCRIPTION

High flow vortex submersible sump pumps with a choice of single or three phase motors.

APPLICATIONS

- Grey water pumping
- Sump emptying
- Septic effluent disposal
- Water transfer
- Pumping of light slurries and factory waste



60Hz models available.

FEATURES & BENEFITS

Corrosion resistant 304 stainless steel shaft, motor shell and fasteners

- Long service life
- Attractive, lasting appearance

Open impeller, vortex, centrifugal design

- Able to pump soft solids in suspension
- Less susceptible to blockage
- Capable of higher flows

Double mechanical shaft seal in oil bath with hard faced silicon carbide / ceramic seal on pump side

- Added motor protection
- Long service life

Sand slinger lip seal

- Added protection
- Long service life

Automatic resetting thermal overload

- Protected against overloading

HO7RNF oil resistant leads, 10 metres long with bared wire lead ends

- Easy to connect to power supply terminations
- Longer life in dirty water

Mounting base fitted

- For a firm and stable positioning during installation and operation

Slide rail kits available

- For easy removal and re-installation

OPERATING LIMITS

Capacities to	2500 lpm
Heads to	13.5 m
Max. submergence	25 m
Max. operating temperature	40°C
Max. soft solids	up to 80% of discharge size

Suitable Fluids

Clean or "grey water" of neutral pH containing up to 20% small soft solids or 1% fine solids. Some wear should be expected while pumping hard solids in suspension.

TECHNICAL SPECIFICATIONS

MATERIALS OF CONSTRUCTION

PART	MATERIAL
Impeller	Cast iron
Pump casing	Cast iron
Outlet	Cast iron
Shaft seal pump side	Silicon carbide/ceramic
motor side	Carbon/ceramic
	Mechanical seals in captive oil bath with oil seal
Shaft seal elastomer	Nitrile rubber
Pump shaft	304 stainless steel
Orings	Nitrile rubber
Motor shell	304 stainless steel
Handle	304 stainless steel
Fasteners	304 stainless steel
Float & power supply leads	HO7RN-F oil resistant

ELECTRICAL DATA

Common to all models	
Insulation class	Class F
IP rating	X8
Electrical lead	HO7RNF x 10m length

D150V	
Supply voltage	220-240V
50Hz - Phase	Single
Speed	2 pole, 2850rpm
Output power	1.5kW
Full load current	13.0A
Locked rotor current	65.0A
Starting	CSIR

	DT15V	DT22V	DT37V	DT55V	DT75V
Supply voltage	380-415V				
50Hz - Phase	Three				
Speed	4 pole, 1450rpm				
Output power	1.5kW	2.2kW	3.7kW	5.5kW	7.5kW
Full load current	3.0A	4.5A	7.5A	12.3A	16.5A
Locked rotor current	22A	31.5A	49A	66A	78A
Starting	DOL				

HYDRAULIC PERFORMANCE

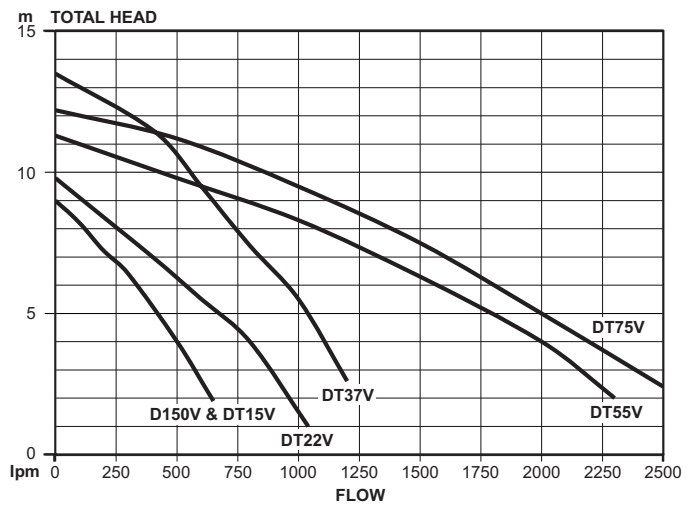

DIMENSIONS

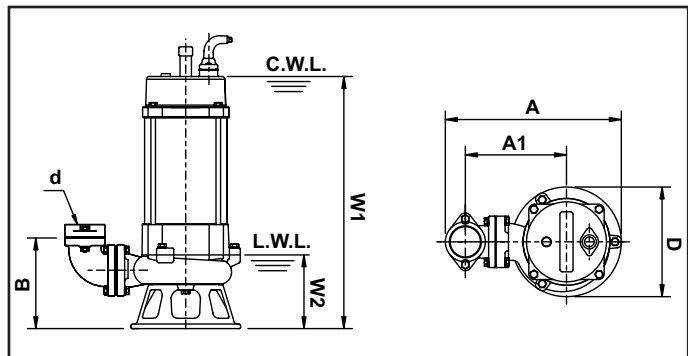

Model	Discharge bore b	A	A1	B	D	H	Operating Water Level W1	Net Water Level W2	Weight (kg)
D150V	3" (80)	395	205	230	195	600	545	200	24
DT15V	3" (80)	395	205	230	195	515	460	200	23
DT22V	3" (80)	430	240	265	255	590	510	240	30
DT37V	3" (80)	430	240	265	255	670	585	240	50
DT55V	4" (100)	660	425	360	315	765	700	310	75
DT75V	4" (100)	660	425	360	315	825	760	310	80

All dimensions in mm unless otherwise stated.

INSTALLATION & PRIMING

Use a rope to position and retrieve the pump. Do not lower or retrieve the pump using the power lead as this may damage the cable entry seals, causing water leaks and unsafe operation. Don't use this product for recirculating or filtering swimming pools, spas, etc. While these pumps are built to high safety standards, they are not approved for installations where people will be in the water while they are operating. Don't pump abrasive materials. Sand and grit in the water being pumped will accelerate wear, causing shortened pump life. Keep your pump clean, particularly in situations where lint, hair or fibrous materials may get bound around the pump shaft. Regular inspection and cleaning will extend pump life. Make room for the float switch to operate. Automatic models have a float switch to turn them on when the water level rises and turn them off again when it has been pumped down to the safe operating level of the pump. If the float switch is not free to rise and fall, correct pump operation may not be possible. Don't run your pump dry. Non-automatic models must be switched off manually or by way of an external float/level switch when the water level is reduced to the top of the pump housing.

This literature is not a complete guide to product usage. Further information is available from your Davey dealer, Davey Customer Service Centre and from the relevant product Installation and Operating Instructions. This data sheet must be read in conjunction with the relevant product Installation and Operating Instructions and all applicable statutory requirements. Product specifications may change without notice. © Davey is a registered trademark of Davey Water Products Pty Ltd. © Davey Water Products Pty Ltd 2008.



DEPEND ON
DAVEY

WATER PRODUCTS

Davey Water Products Pty Ltd International

Member of the GUD Group
ABN 18 066 327 517
Head Office and Manufacturing
 6 Lakeview Drive,
 Scoresby, Australia 3179
 Ph: +61 3 9730 9222
 Fax: +61 3 9753 4100
 Website: davey.com.au
Customer Service Centre
 Ph: 1300 367 866
 Fax: 1300 369 119
 E-mail: sales@davey.com.au
Interstate Offices
 Sydney • Brisbane • Adelaide
 Perth • Townsville

6 Lakeview Drive,
 Scoresby, Australia 3179
 Ph: +61 3 9730 9121
 Fax: +61 3 9753 4248
 E-mail: export@davey.com.au

Germany
 Kantstrasse 53,
 04275 Leipzig
 Ph: +49 341 301 0412
 Fax: +49 341 301 0413
 E-mail: akrenz@daveyeurope.com

New Zealand
 7 Rockridge Avenue,
 Penrose, Auckland 1330
 Ph: +64 9 570 9135
 Fax: +64 9 527 7654
 Website: daveynz.co.nz
 E-mail: sales@daveynz.co.nz

USA - Davey Pumps Inc.
 1005 N. Commons Drive
 Aurora, Illinois 60504
 Ph: +1 630 898 6976
 Fax: +1 630 851 7744
 Website: daveyusa.com
 E-mail: sales@daveyusa.com