

**RVM SERIES
PACKAGED WATER PRESSURE SYSTEMS
UP TO 40m³/hr**

DEPEND ON
DAVEY

WATER PRODUCTS

PACKAGED WATER PRESSURE SYSTEMS

PRODUCT DESCRIPTION

RVM pumpsets are a single pump packaged system that comes in three versions.

1. RVM Water Pressure System
2. RVM Water Pressure System with LOP Control Box
3. RVM Remote Start/LOP Pump Set

APPLICATIONS

Automatic water pressure system for:

- Irrigation & turf watering
- Stock watering
- Water supply, boosting & transfer
- Industrial applications
- Water treatment

OPERATING LIMITS

Capacities to	11 l/s (40m ³ /hr)
Pressure heads to	160 m
Maximum liquid temperature	+70°C (tank)
Maximum ambient temperature	+40°C
Maximum inlet pressure	Limited by max. operating pressure
Maximum operating pressure with 105C Tank	70m/700kPa
Maximum operating pressure with HP105C Tank	105m/1050kPa
Maximum operating pressure with HP24+ Tank	160m/1600kPa

Suitable Fluids

Clean, clear, non-corrosive, non-flammable liquids with no fibres and little sand/silica or abrasives (maximum concentration 40g/m³).

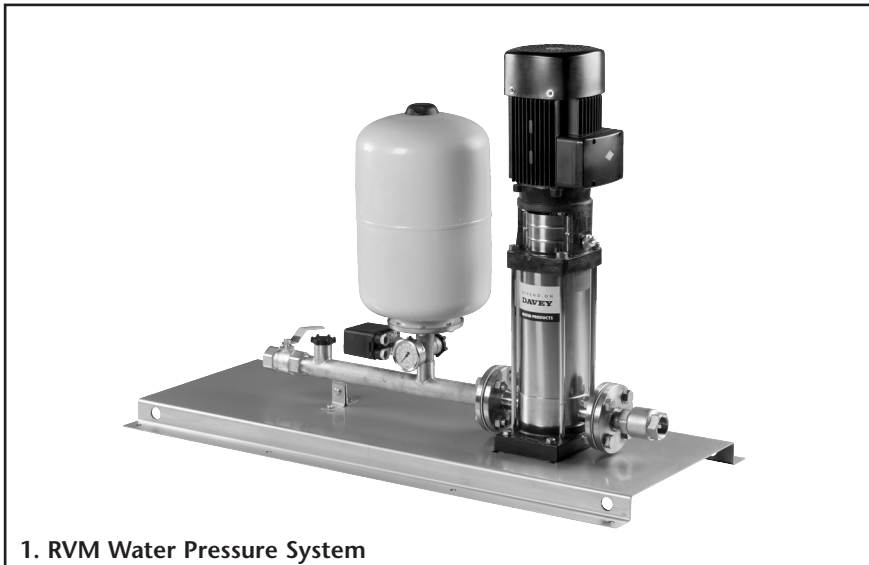

1. RVM Water Pressure System



2. RVM Water Pressure System with LOP Control Box

Loss of Prime Protection



3. RVM Remote Start/LOP Control Box

Remote Start

Loss of Prime Protection

TECHNICAL SPECIFICATIONS

FEATURES & BENEFITS

RVM Water Pressure System

The packaged water pressure version consists of a Davey VM vertical multistage pump, with the choice of either a 24 litre, or 105 litre pressure tank, manifold, adjustable pressure switch, liquid filled pressure gauge, check and isolation valves all mounted on a common base plate. (Note: the 105 litre tank is free standing).

RVM Water Pressure System with Loss-of-Prime Protection

The loss-of-prime version uses all of the components of the water pressure version and adds a control box and flow switch. This provides the benefit of protecting the pump in no-flow situations, such as loss-of-prime and dead head.

The control box offers Auto, Off and Manual control. Manual control will automatically switch over to Automatic control after 2.5 minutes in order to ensure pump protection.

The control box provides indicators such as Power On, Pump Run, Low Flow Alarm and Pump Overload. In a fault condition, the control box provides a light and audible alarm. The audible alarm ceases after 5 minutes.

Because the system is started by pressure and stopped on flow, it is able to provide continuing, though partial, automatic operation in situations where the pump is unable to make the cut-out pressure point. For example, where some rubbish has been sucked into the suction line to cause partial restriction. While the alarm will be activated, the pump will restart so long as there is some flow demand.

RVM Remote Start/LOP Pump Set

The remote start/LOP version includes a Davey VM vertical multistage pump, manifold, liquid filled pressure gauge, remote start control box, flow switch, check and isolation valves all mounted on a common base.

The pump is turned on and off by a 24VAC signal to the control box, which is ideal for use with irrigation controllers and external sensors. The control box provides pump protection in no-flow situations, such as loss of prime or stuck closed irrigation valve.

COMMON FEATURES & BENEFITS

Fully Assembled

Systems are supplied fully assembled for ease of mounting – Supercell 105C tanks are supplied free standing. Optional 304 stainless steel base plates are also available.

Extra Low Voltage Controls

All pressure and flow switches for LOP models are 5VDC for added safety and ease of maintenance.

Plug in and Pump

All 240V single phase units up to 2.2kW come completely pre-wired with power leads and three pin plug for connection to G.P.O. – no need for an electrician on site. Larger single phase and all three phase units simply require connection to power by an electrician.

DOL or Soft Start

All 5.5 and 7.5kW, three phase units are available in both DOL or soft start versions to satisfy the requirements of various power authorities.

Proven Dependability

The Davey VM pumps and supercell tanks have proven themselves around the world. All VM vertical multistage pump hydraulic parts are manufactured from 304 stainless steel, providing corrosion protection.

High Efficiency

Powered by an IP55 motor suitable for some of the harshest operating conditions. All three phase motors comply with the high efficiency MEPS (Minimum Energy Performance Standards) requirements.

TECHNICAL SPECIFICATIONS

MOTOR TECHNICAL SPECIFICATIONS

Motor	Frame	IP Rating	FLC 240 V	Start/LRC Ratio	RPM	Eff %	Bearings	
							Drive End	Non-D/End
0.75	80 V18	IP56	4.38	5.83	2815	72	6204-ZZ	6204-ZZ
1.1	80 V18	IP56	6.38	5.65	2830	75	6204-ZZ	6204-ZZ
1.5	90 V18	IP56	8.08	5.57	2850	76	6205-ZZ	6205-ZZ
2.2	90 V18	IP56	12.0	4.59	2830	77	6205-ZZ	6205-ZZ
3.0	100 V18	IP56	18.0*	5.0	2870	81	6206-ZZ	6205-ZZ
4.0	112 V18	IP56	22.0*	6.4	2910	84	6207-ZZ	6206-ZZ

*For 480V single phase operation multiply by 0.5.

Motor	Frame	IP Rating	FLC 415 V	Start/LRC Ratio	RPM	Eff %	Bearings	
							Drive End	Non-D/End
0.75	80 V18	IP55	1.6	5.5	2800	89.0	6204-ZZ	6204-ZZ
1.1	80 V18	IP55	2.2	6.2	2828	82.4	6204-ZZ	6204-ZZ
1.5	90 V18	IP55	3.1	5.3	2800	78.0	6205-ZZC3	6205-ZZC3
2.2	90 V18	IP55	4.2	6.7	2800	85.0	6205-ZZC3	6205-ZZC3
3	100 V18	IP55	5.7	6.8	2853	86.2	6206-ZZC3	6206-ZZC3
4	112 V18•	IP55	7.3	6.7	2902	86.8	6306-S	6306-S
5.5	132 V1•	IP55	9.8	7.4	2916	89.9	7308B	6308ZZC3
7.5	132 V1•	IP55	13.3	7.4	2892	87.0	7308B	6308ZZC3

•Special motor bearings fitted for thrust management.

HYDRAULIC PERFORMANCE

VM3, 2 POLE 50Hz

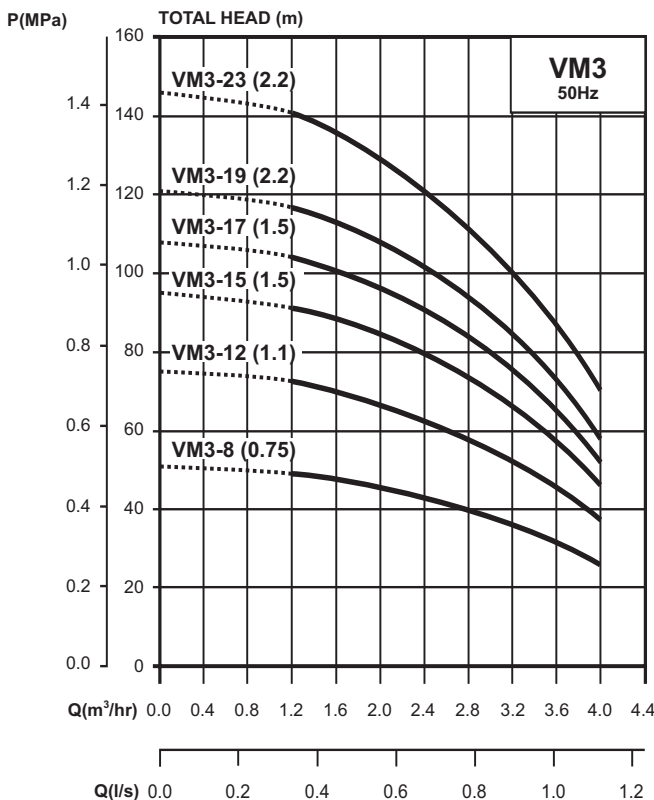

VM5, 2 POLE 50Hz

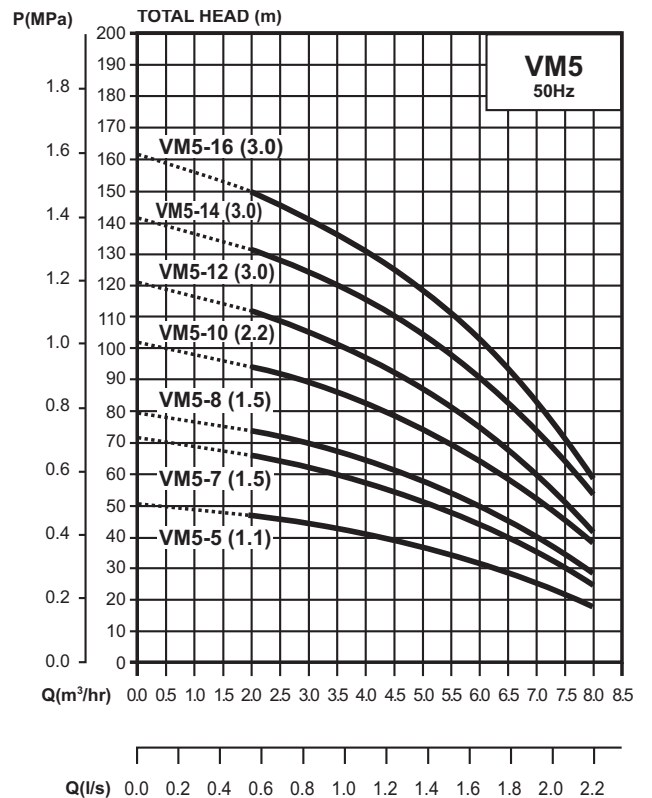

NOTE: CURVE TOLERANCE IN CONFORMITY WITH ISO9906 APPENDIX A.

TECHNICAL SPECIFICATIONS

HYDRAULIC PERFORMANCE

VM10, 2 POLE 50Hz

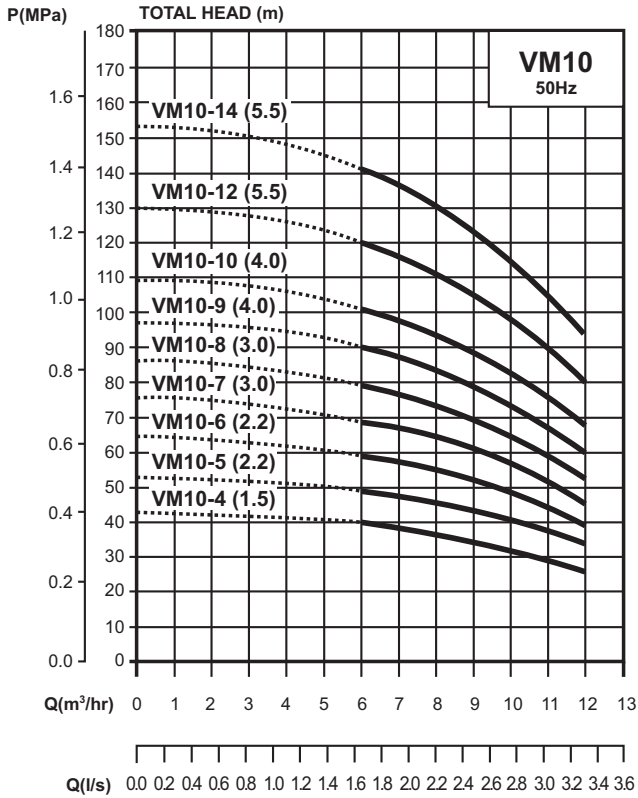

VM16, 2 POLE 50Hz

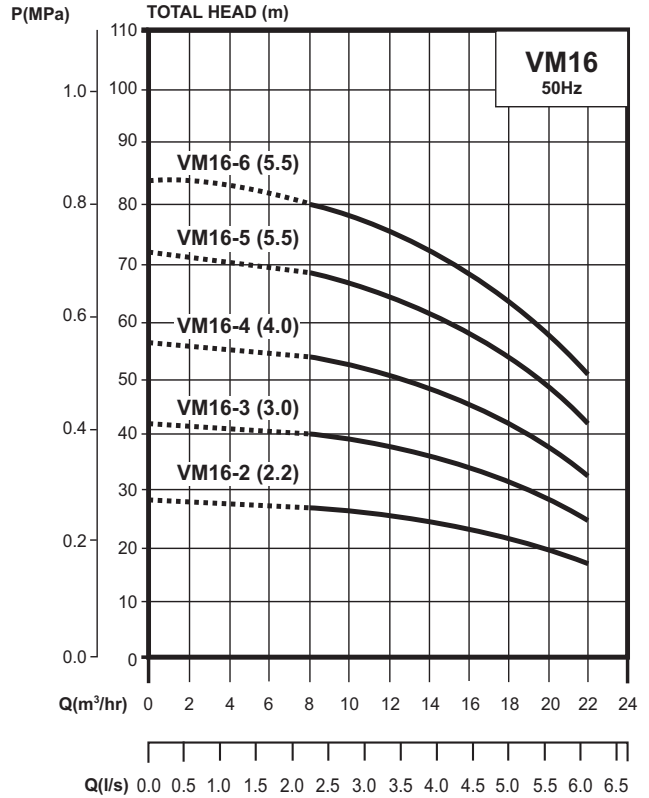

VM32, 2 POLE 50Hz

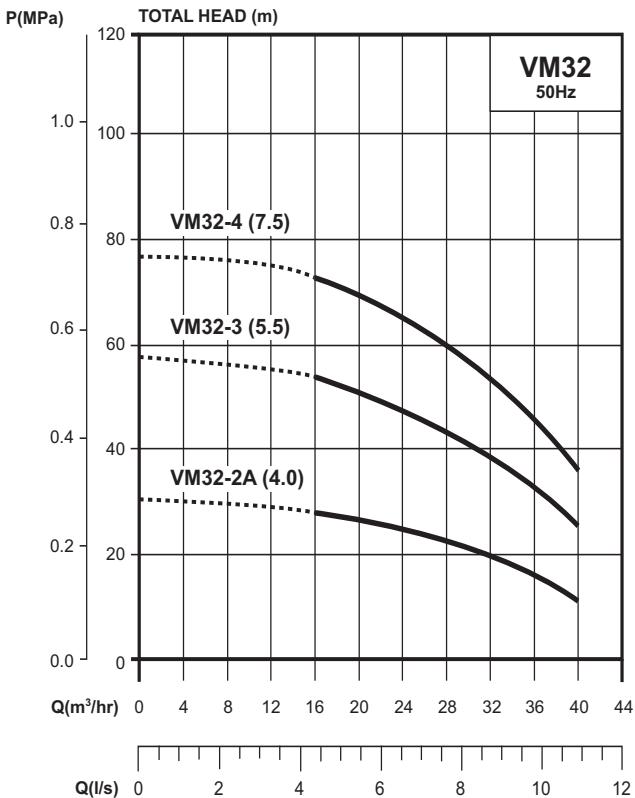

MATERIALS OF CONSTRUCTION

PART	MATERIAL
Pump attachment base	Cast iron
Suction & discharge casing	304 stainless steel
Motor support lantern	Cast iron
Impellers	304 stainless steel
Stages (casing)	304 stainless steel
Outside sleeve	304 stainless steel
Pump shaft	316L stainless steel
Intermediate bearing	Tungsten carbide
Mechanical seal	Silicon carbide/carbon/EPDM
Orings (casing)	EPDM
Plugs (drainage & priming)	316L stainless steel
Impeller neck rings	Teflon

* Special version with 316L stainless steel & viton orings on request

NOTE: **304 stainless steel**, (Z6 CN 18.9) and **316L stainless steel** (Z2 CND 17.12) are recommended materials that are highly resistant to corrosion. Suitable for pumping clean, clear non-viscous liquids, containing no fibres or solids. Maximum sand/silica concentration 40 g/m³.

NOTE: CURVE TOLERANCE IN CONFORMITY WITH ISO9906 APPENDIX A.

TECHNICAL SPECIFICATIONS

IDENTIFICATION OF THE PUMP SET

RVM 3 - 8 A/3 - 24 - L

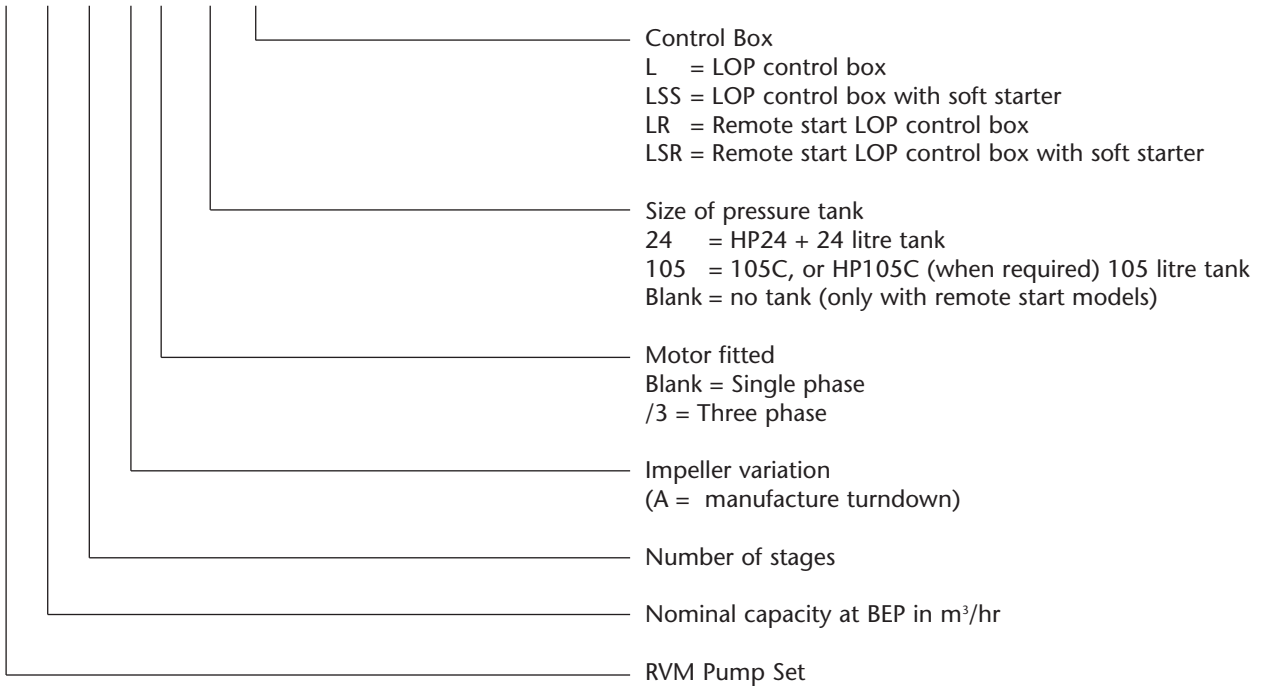

WATER PRESSURE SYSTEM WITH 24 LITRE TANK

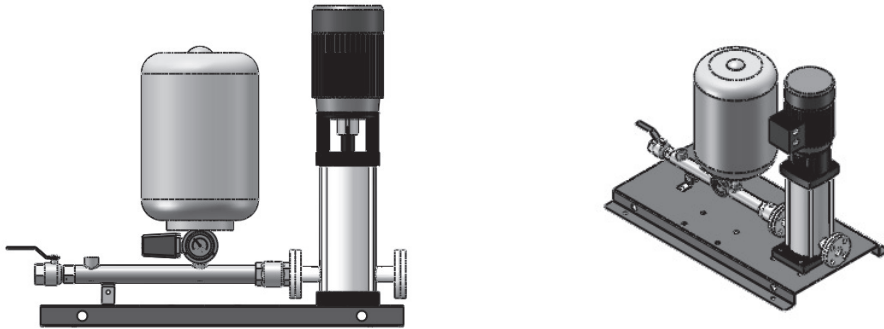

WATER PRESSURE SYSTEM WITH LOP CONTROL BOX AND 24 LITRE TANK

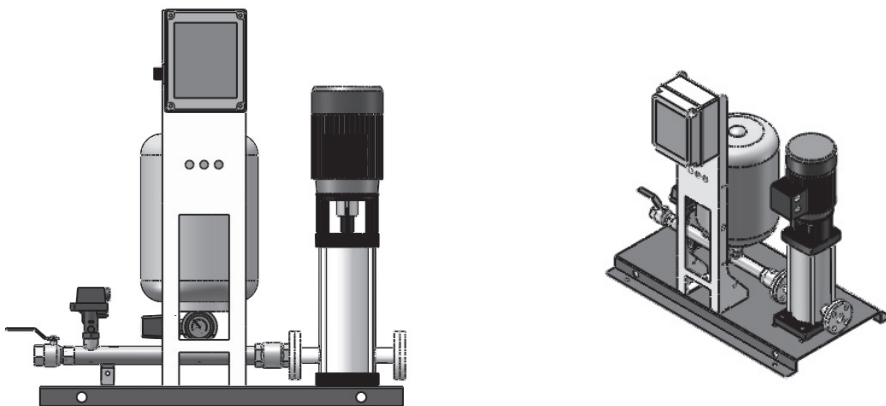

TECHNICAL SPECIFICATIONS

WATER PRESSURE SYSTEM WITH 105 LITRE TANK

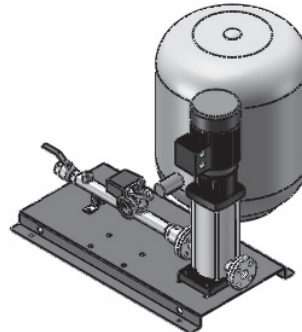
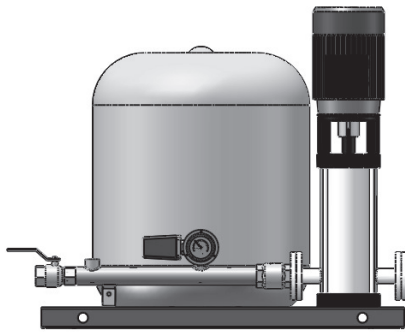

WATER PRESSURE SYSTEM WITH LOP CONTROL BOX AND 105 LITRE TANK

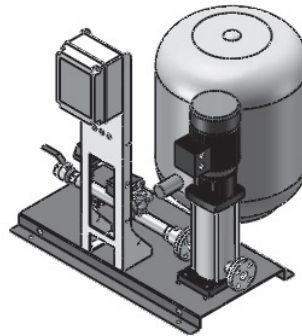
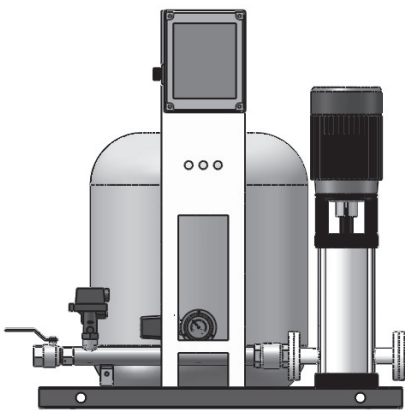

REMOTE START/LOP PUMP SET

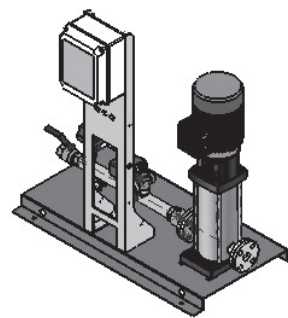
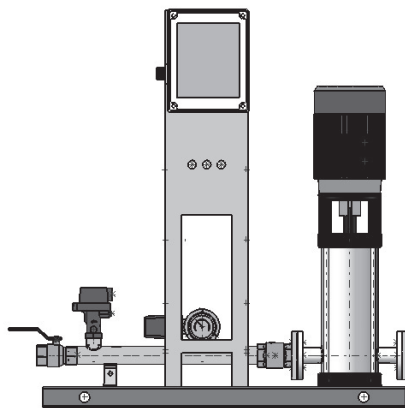

Specific dimensions for each model available on request. Davey reserves the right to change dimensions and configurations without notice.

This literature is not a complete guide to product usage. Further information is available from your Davey dealer, Davey Customer Service Centre and from the relevant product installation and Operating Instructions. This data sheet must be read in conjunction with the relevant product Installation and Operating Instructions and all applicable statutory requirements. Product specifications may change without notice.

© Davey is a registered trademark of Davey Water Products Pty Ltd. © Davey Water Products Pty Ltd 2000.



Visit Davey on-line for further information
davey.com.au

DEPEND ON
DAVEY

WATER PRODUCTS

Davey Water Products Pty Ltd

Member of the GUD Group
ABN 18 066 327 517

Head Office and Manufacturing

6 Lakeview Drive,
Scoresby, Australia 3179
Ph: +61 3 9730 9222
Fax: +61 3 9753 4100
Website: davey.com.au

Customer Service Centre

Ph: 1300 367 866
Fax: 1300 369 119
E-mail: sales@davey.com.au

Interstate Offices

Sydney • Brisbane • Adelaide
Perth • Townsville

International

6 Lakeview Drive,
Scoresby, Australia 3179
Ph: +61 3 9730 9121
Fax: +61 3 9753 4248
E-mail: export@davey.com.au

Germany

Kantstrasse 53,
04275 Leipzig
Ph: +49 341 301 0412
Fax: +49 341 301 0413
E-mail: akrenz@daveyeurope.com

USA

Ph: +1 630 898 6976
Website: daveyusa.com
E-mail: sales@daveyusa.com

Davey Water Products – New Zealand

7 Rockridge Avenue,
Penrose, Auckland 1061
Ph: +64 9 570 9135
Fax: +64 9 527 7654
Website: daveynz.co.nz
E-mail: sales@daveynz.co.nz

Davey Spa – New Zealand

2 Rothwell Avenue,
North Harbour, Auckland 0632
Ph: +64 9 415 8622
Fax: +64 9 415 8621
Website: spa-quip.co.nz
E-mail: service@spa-quip.co.nz