

Davey® Repair or Replacement Guarantee

In the unlikely event in Australia or New Zealand that this Davey product develops any malfunction within warranty periods beginning from the date of original purchase due to faulty materials or manufacture, Davey will at our option repair or replace it for you free of charge, subject to the conditions below.

Davey Guarantee Period

Steriflo Controller - One Year

Steriflo Lamp - Six months

Should you experience any difficulties with your Davey product, we suggest in the first instance that you contact the Davey Dealer from which you purchased the Davey product. Alternatively you can phone our Customer Service line on 1300 367 866 in Australia, or 0800 654 333 in New Zealand, or send a written letter to Davey at the address listed below. On receipt of your claim, Davey will seek to resolve your difficulties or, if the product is faulty or defective, advise you on how to have your Davey product repaired, obtain a replacement or a refund.

Your Davey Guarantee naturally does not cover normal wear or tear, replacement of product consumables (i.e. mechanical seals, bearings or capacitors), loss or damage resulting from misuse or negligent handling, improper use for which the product was not designed or advertised, failure to properly follow the provided installation and operating instructions, failure to carry out maintenance, corrosive or abrasive water or other liquid, lightning or high voltage spikes, or unauthorized persons attempting repairs. Where applicable, your Davey product must only be connected to the voltage shown on the nameplate.

Your Davey Guarantee does not cover freight or any other costs incurred in making a claim. Please retain your receipt as proof of purchase; you **MUST** provide evidence of the date of original purchase when claiming under the Davey Guarantee.

Davey shall not be liable for any loss of profits or any consequential, indirect or special loss, damage or injury of any kind whatsoever arising directly or indirectly from Davey products. This limitation does not apply to any liability of Davey for failure to comply with a consumer guarantee applicable to your Davey product under the Australian or New Zealand legislation and does not affect any rights or remedies that may be available to you under the Australian or New Zealand Consumer Legislation.

In Australia, you are entitled to a replacement or refund for a major failure and for compensation for any other reasonably foreseeable loss or damage. You are also entitled to have the goods repaired or replaced if the goods fail to be of acceptable quality and the failure does not amount to a major failure.

Should your Davey product require repair or service after the guarantee period; contact your nearest Davey Dealer or phone the Davey Customer Service Centre on the number listed below.

For a complete list of Davey Dealers visit our website (davey.com.au) or call:



AUSTRALIA
Customer Service Centre
 6 Lakeview Drive,
 Scoresby, Australia 3179
 Ph: 1300 367 866
 Fax: 1300 369 119
 Website: davey.com.au

NEW ZEALAND
Customer Service Centre
 7 Rockridge Avenue,
 Penrose, Auckland 1061
 Ph: 0800 654 333
 Fax: 09 527 7654
 Website: daveynz.co.nz

Davey Water Products Pty Ltd
 Member of the GUD Group
 ABN 18 066 327 517

© Davey & Steriflo are registered trade marks of Davey Water Products Pty Ltd.
 © Davey Water Products Pty Ltd 2011.

P/N 400281-10 supersedes P/N 400281-9



Installation and Operating Instructions for Davey STERIFLO® Ultra Violet Water Treatment System



! Minimum operating pressure is 0kPa. Installation on a flooded suction is recommended. Installation under vacuum is not advised, any damage to persons or associated equipment will not be covered under this guarantee.

! Maximum operating pressure for stainless steel UV chambers is 850kPa (125 psi). If this pressure can be exceeded or if operating close to this pressure fit a suitable pressure limiting valve in the supply to the UV chamber.

! **WARNING:** The UV Chamber operates under pressure. Under no circumstances should the UV Chamber be disassembled unless the internal pressure of the unit has been relieved. Failure to observe this warning will expose persons to the possibility of personal injury and may result in damage to the UV system or other property.

!  Ultra violet radiation is harmful to skin & eyes.
DO NOT LOOK AT UV LAMP WHILE LAMP IS OPERATING.

! **DO NOT DISASSEMBLE ANY COMPONENTS UNTIL YOU HAVE FULLY READ THESE INSTRUCTIONS!**

! This unit is designed to treat water at ambient temperatures (5oC to 45oC). Contact your dealer for details of UV systems suitable for hot water service.

Please pass these instructions on to the operator of this equipment.

* Installation and operating instructions are included with the product when purchased new. They may also be found on our website.

Table of Contents

Introduction	3
Preparing your system	3
Choosing a Site	4
Housing your Davey Steriflo System	4
Power Connection	5
Electrical Power Surge Protection	5 - 6
Pipe Connections	6
Pre-treatment (drinking water)	6
Lamp Installation	7
Operation	7
Maintenance	8 - 9
Water Quality	9
Lamp Fail Alarm	9
Trouble Shooting	9 - 10
Service Parts	10
Warning - UV Radiation	11



Ultra violet radiation is harmful to skin & eyes.
DO NOT LOOK AT UV LAMP WHILE LAMP IS OPERATING.

EYES
 Switch off UV system before removing covers. If working within line of sight of UV light, ensure that a suitable full face plastic facemask is worn.

SKIN
 It is recommended that exposed skin is covered to prevent sunburn, possibly severe, if working within line of sight of operating UV system.
 Note: exposure to UV light results in symptoms that develop slowly, the exposure cannot be felt at the time.

SYMPTOMS
EYES: Mild exposure - irritation developing several hours later.
 Severe exposure - sore, red eyes, sensitive to light, painful to keep eyes open.
SKIN: Mild exposure - slight reddening, tenderness, mild sunburn symptoms.
 Severe exposure - skin sloughing (peeling), weeping area, severe sunburn symptoms.

FIRST AID
EYES: In mild cases, if in doubt seek medical attention.
 Severe cases cover eyes with gauze or clean cloth, seek medical attention.
SKIN: In mild cases removal from exposure may be sufficient. If in doubt seek medical attention.
 In severe cases, cover affected area loosely with a clean bandage or cloth. Seek medical attention. Do not apply fat, butter or oil to skin.

The above notes are intended to highlight the dangers of exposure to UV radiation. With sensible precautions any hazard can be eliminated. Germicidal UV cannot pass through clothing or other opaque materials or clear materials such as plastics or even window glass.



During service **DO NOT** use lubricants or sealants of any type on the orings. Keep the inside of the quartz sleeve dry and clean.



WARNING - Do not use hydrocarbon based or hydrocarbon propelled sprays around the electrical components of this unit.

Trouble Shooting continued...

- b) UV LAMP FLICKERING, ALARM ON
1. Failed lamp.
 2. Incorrect starter (use only S300 electronic starter in UV40-20 & UV75-25, UV130-40 has no starter).
 3. Incorrect lamp or ballast fitted.
- c) UV LAMP OUT, ALARM ON
1. Lamp failed.
 2. Poor connection to lamp (check/clean connector/lamp pins).
 3. Starter failed or loose in socket (not applicable to UV130-40).
 4. Ballast failed (unlikely).
- d) LAMP ON, ALARM ON
1. Faulty circuit board.
- e) LAMP OUT, ALARM OFF
- Loose connection, faulty circuit board or possibly faulty lamp.



WARNING: When servicing or attending your Steriflo®, always ensure power is switched off and lead unplugged. Electrical connections should be serviced only by qualified persons. If the electrical supply lead of this system is damaged, it must only be replaced by authorised Davey service personnel as special tools are required.



Care should also be taken when servicing or disassembling the unit and associated pipework to avoid possible injury from pressurised water. Unplug power, relieve pressure by opening a tap on the discharge side of the unit and allow any water in the unit to cool before attempting to dismantle.

Service Parts

Replacement Lamp

Suit UV40-20 & UV75-25	GPH840N/S
Suit UV130-40	GPH840N2/S

Sleeve

Suit UV40-20 & UV75-25	QS834
Suit UV130-40	QS880

Starter

Suit UV40-20 & UV75-25	S300
Suit UV130-40	No starter

Orings

All models	S24x3N70 (2 per sleeve)
------------	-------------------------

Lamp Connector

All models	S114/2
------------	--------

Congratulations on your purchase of a high quality, Davey Steriflo® Ultra Violet water treatment system. All components have been designed and manufactured to give trouble free, reliable operation.

Your new Steriflo® system incorporates a lamp failure system design feature that enables you to be warned of a lamp failure by :-

1. A lamp failure red LED
2. An audible alarm
3. Remote alarm contacts (only in UV130-40 MkII)

In addition the UV130-40 mkII features a UV timer. When the alarm “beeps” on and off, the lamp is due to be changed so that effective treatment is maintained.

As part of the timing function, the red LED will flash quickly once every ten seconds, but the alarm will not sound. This is **not** a fault indication.

Before installing your new Steriflo®, please read all instructions carefully as failures caused by incorrect installation or operation are not covered by the guarantee. Your Ultra Violet water treatment system is designed to handle clean water. The system should not be used for any other purpose without specific referral to Davey. The use of the system with flammable, corrosive and other materials of a hazardous nature is specifically excluded.

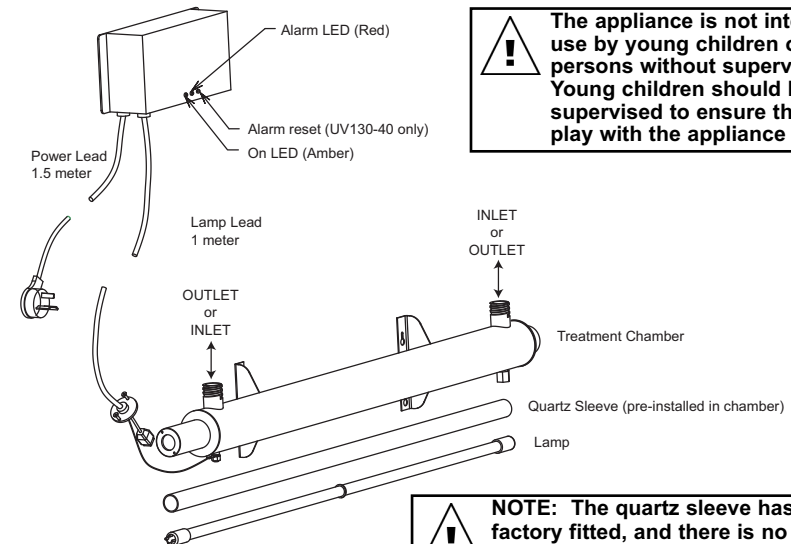

The appliance is not intended for use by young children or infirm persons without supervision. Young children should be supervised to ensure they do not play with the appliance



NOTE: The quartz sleeve has been factory fitted, and there is no need to remove these endcaps on first installation. Before removing endcaps, please read the Maintenance section of these instructions completely.

Preparing your system

On removing your Steriflo® system from its carton you should check all components, especially the lamp, to ensure all are present and have not been damaged in transportation. You should have :-

1. Power supply control box with indicator light and electrical flex.
2. UV lamp.
3. Treatment chamber with mounting brackets.

Choosing a Site

Choose a site with a firm mounting position. Allow room for removal of the lamp and sleeve during servicing. Leave a chamber lengths space at the lamp connector end for lamp removal, with 100mm free at the other end for access to the end nut. The 'open' end nut and the blank end nut are interchangeable, so lamp removal can be from either end.

Housing your Davey Steriflo® System

To protect your Davey Steriflo® system from the weather, make sure the site is both water proof, frost free and has adequate ventilation. The unit should be either horizontally mounted with the inlet and outlet facing upwards or vertically mounted with the inlet at the bottom. Allow for drainage, to avoid damage to flooring etc., that over time may occur from leaking pipe joints or seals.



WARNING: Some insects, such as small ants, find electrical devices attractive for various reasons. If your site or enclosure is susceptible to insect infestation you should implement a suitable pest control plan.

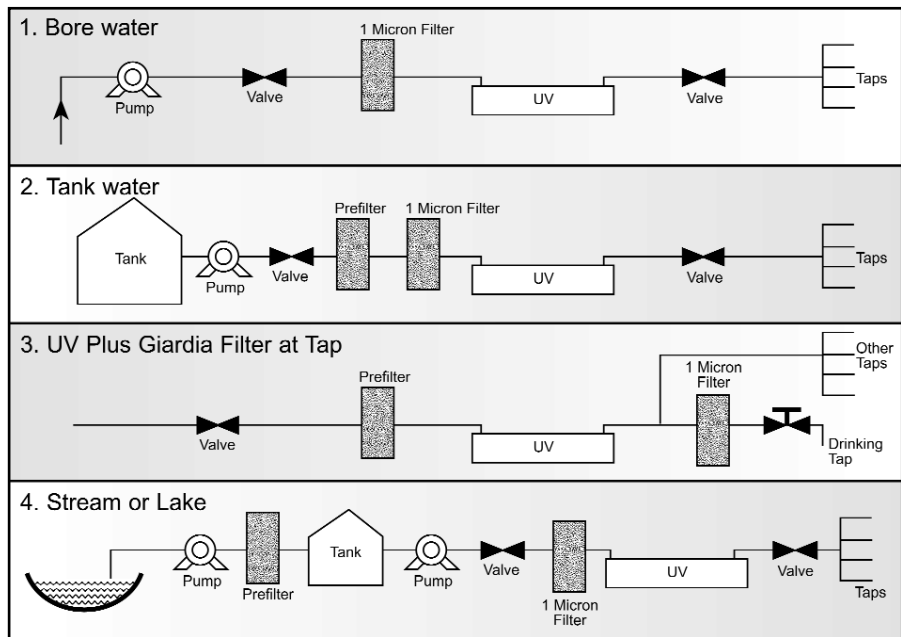

Maintenance continued...

Reverse procedure when replacing sleeve.

When replacing quartz sleeve after cleaning, the sleeve should stick out about 1cm at each end. Place oring over closed nut end and fit closed nut, fastening it hand tight. Hold the other end of the sleeve in position during the tightening with the other hand, then fit open end oring and cap.

A tiny amount of silicon spray or CRC in the end of aluminium endcap threads will aid easy tightening. Do not use excessive force when tightening nuts. Do not re-use quartz sleeve if damaged.

Water Quality

Where the water being pumped contains unusually high levels of dissolved solids (hard water), iron, manganese or biological organisms, a deposit build up on the quartz sleeve may occur over time. This will compromise the effectiveness of the UV system and the sleeve should be cleaned as required to maintain it in a clean condition. Discoloured water will reduce the effectiveness of the UV system and filtration should be installed.

Lamp Fail Alarm - UV40-20 & UV75-25

All models are fitted with an alarm buzzer which sounds if the lamp is not running. To test the alarm, switch off the power to the Steriflo® at the mains and unplug, disconnect the UV lamp (white socket inside long endcap) and switch the power on again, the alarm should now sound.

Lamp Alarm System - UV130-40

If the UV lamp is out due to a failure or bad connection the alarm buzzer will sound and the red LED will light. If fitted, the optional alarm contacts will changeover. These are able to close a normally open solenoid valve. The alarm function can be checked by switching the unit off, disconnecting the lamp and then switching the unit back on.

The lamp should be replaced after a year's running time. The alarm will beep intermittently after the internal clock has measured this time as a reminder to change the lamp. Pressing the recessed 'reset' button with a ballpoint pen will silence it for 24 hours at a time to allow time for a new lamp to be obtained. Once a new lamp is installed press the reset button for 5 seconds to start another year's timing. Do this whenever a new lamp is installed.

Trouble Shooting

Principle. The basic electrical circuit is like a fluorescent light. A ballast (choke) provides the correct voltage and current for the lamps, a starter provides a high voltage to start the lamp. The circuit board monitors the current to the lamp and if it is not present, illuminates the red alarm light and sounds the alarm buzzer (a "squealing" noise). An orange light indicates the power is on.

- a) UV LAMP OUT, NO ORANGE "ON" LIGHT, NO ALARM
 - 1. No mains voltage.
 - 2. Internal fuse failed.
 - 3. Check mains power connections inside power supply.

Maintenance

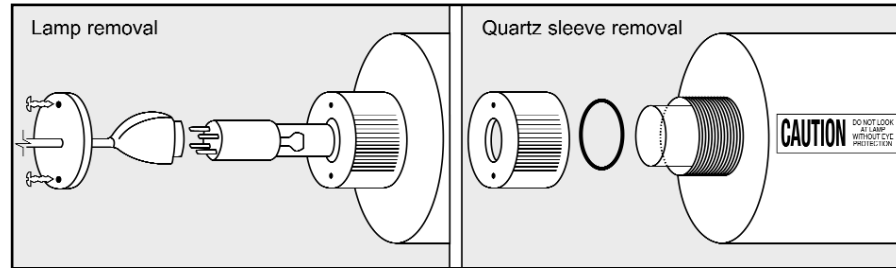

Lamp changing (every year of operation) :-

1. Shut valve(s) so that water cannot flow through steriliser.
2. Switch off steriliser by unplugging mains.
3. Unplug lamp connector.
4. Remove lamp.

Reverse procedure when replacing lamp, ensuring that lamp is centrally located in the chamber. Handle only by the ends.

Quartz Sleeve Cleaning (three monthly) :-

If dirt is allowed to build up on the quartz sleeve it will impair the UV output. The quartz sleeve should be removed after one month and inspected for deposits. Clean with methylated spirits (5% hydrochloric acid if heavily fouled) and carefully dry. Handle the sleeve with tissue to keep it clean. The sleeve should be cleaned every three months or as required.

Sleeve removal (use care-fragile) :-



CAUTION: Handling lamp and quartz sleeve. Keep the quartz components free of finger marks to avoid loss of output through dirt or grease shadows - handle the lamps by their ends where possible. Wipe lamp and sleeve with clean cloth or tissue if needed. The o-rings should be replaced annually or if damaged – do not grease the o-rings.

1. Remove lamp as described.
2. Remove drain port cap and empty water from chamber.
3. Undo nut at one end of the chamber and remove oring, repeat with nut at other end and remove oring, withdraw sleeve carefully.



NOTE: When withdrawing sleeve take care not to let the end drop into the chamber as it could break - a clean dowel inserted right through the sleeve to support it is useful.

4. Inspect orings for damage, replace annually.

Power Connection



WARNING: When servicing or attending your Steriflo®, always ensure power is switched off and lead unplugged. Electrical connections should be serviced only by qualified persons. If the electrical supply lead of this system is damaged, it must only be replaced by authorised Davey service personnel as special tools are required.

Connect lead to power supply designated on control box label. Do not use long extension leads as they cause substantial voltage drop and/or poor lamp performance. Earth stainless steel chambers using bolt provided on the chamber (see illustration below).



Install the power supply enclosure above the treatment chamber so that in the event of a leak, water cannot drip down the lamp lead into the enclosure. CAUTION: The supply cord is necessary for lamp changing. The three pin supply plug must remain accessible after installation. If installed to fixed wiring without the plug a two pole switch must be fitted and its ON and OFF positions shall be marked.



The Davey Steriflo® control box has a red LED alarm indicator light mounted on its front panel, adjacent to the amber “power on” LED. This light will be illuminated whenever the Steriflo® control box senses lamp failure. There is also an audible alarm in the event of lamp failure. The LED and/or alarm will only work when unit is connected to the correct electrical supply.

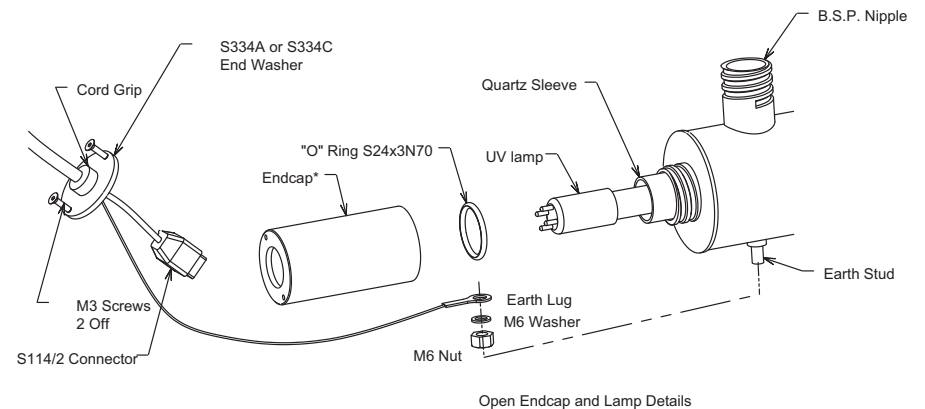

*Models UV40-20 and UV75-25 use long endcap P/No. S168A, UV130-40 use short endcap P/N S333A.

Electrical Power Surge Protection

An electrical power surge or spike can travel on the supply lines and cause serious damage to your electrical equipment. The Steriflo® control box has a 2 AMP fuse to protect the circuit. The fuse is not a lightning arrester and may not protect the Steriflo® if lightning or a very powerful surge hits the unit.

Electrical Power Surge Protection continued...

If the installation is subject to electrical power surges or lightning we strongly recommend the use of suitable additional surge protection devices on ALL electrical equipment.

Davey also recommend the use of an RCD or earth leakage circuit breaker on the power supply to your unit.

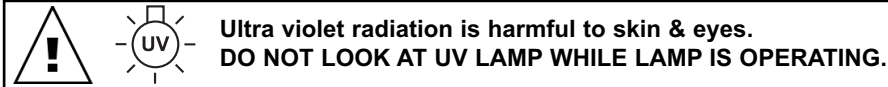

Pipe Connections

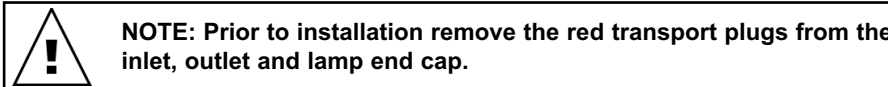

For best performance use copper, stainless steel, galvanised or polythene pipes at least the same diameter as the inlet and outlet connections. Never use PVC pipe directly connected to unit. PVC pipe and fittings can be used after 90° bends of a suitable material are connected to the inlet and outlet of the chamber. Larger diameter pipe may be used to minimise resistance to flow, but maximum flow rates should not be exceeded, as correct water treatment cannot be assured at higher flows. If flows may exceed the design maximum, install a flow restriction device.

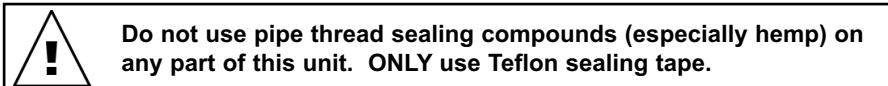

Use unions at pipe connections to enable easy removal and servicing. Use sufficient tape to ensure airtight seal and do not over tighten. To prevent strain on unit threads always support heavy inlet and outlet pipes. If there is a likelihood the water supply may contain sediment or solid particles such as pieces of plant or vegetable matter, a filter should be installed before the Steriflo®.

Pre-treatment (drinking water)

Prefiltration is usually required to ensure that particulate matter does not shield micro-organisms from the UV light. Sand filtration or 20 micron cartridge filtration is the usual minimum. In some cases, particularly with surface water, finer filtration may be necessary, or if cysts like Giardia or Cryptosporidium may be present. In this case 1 micron filtration is required, not necessarily for the whole supply, filtration for the drinking tap only may be practical.

Lamp Installation

Once the Steriflo® Treatment Chamber has been connected to the pipework, the installation should be checked for water leaks.

Attach the “DO NOT LOOK AT LAMP” sticker in an obvious position on the treatment chamber, check that the chamber is clean to ensure the sticker will adhere correctly.

The Quartz Sleeve is pre-installed in the treatment chamber, and provided the endcaps have not been disturbed or undone, is able to withstand well in excess of the maximum operating pressures.

If the chamber test is successful, it is now time to insert the lamp. **DO NOT INSERT THREE PIN POWER PLUG TO POWER OUTLET YET!**

Expose the connection end of the lamp from its transport tube and protective wrapping. The lamp connection socket is “keyed” to ensure correct alignment. Carefully remove the tube fully from its transport tube, touching the lamp as little as possible. Handle the lamp by the ends where possible. Wipe with clean cloth and methylated spirits if fingerprints or dirt need removing.

Slide the lamp into the chamber, fit lamp connection socket and then fasten the end washer into the endcap, with the screws provided.

Operation

Once all leak testing and lamp fitment has been completed, open valves and allow water to fill the chamber. Connect three pin plug to outlet and switch on. The “Mains On” Amber LED will be illuminated. For the UV130-40 MkII, the red alarm light will flash slowly as well.

Allow two minutes for the UV lamp to reach full intensity before starting water flow. Full lamp performance for a new installation will be achieved in 24 hours. On a new installation where no other form of sterilisation has been in constant usage we recommend chemically dosing your rainwater tank with Acquasafe for the first month. Acquasafe is tasteless and is suitable for use in drinking water. Alternatively you can use a Chlorine flush of the plumbing downstream of the Steriflo® system. Use a 20mg per litre dose and leave the chlorine dose in the plumbing at least for an hour, and preferably overnight.

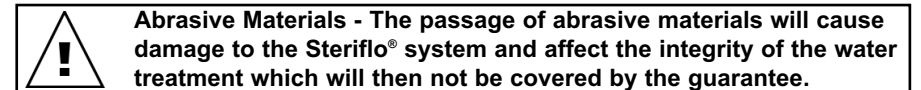

Davey Water Products Pty Ltd can not accept responsibility for loss or damage resulting from incorrect or unauthorised installations.