

## Davey® Repair or Replacement Guarantee

In the unlikely event in Australia or New Zealand that this Davey product develops any malfunction within two years of the date of original purchase due to faulty materials or manufacture, Davey will at our option repair or replace it for you free of charge, subject to the conditions below.

Should you experience any difficulties with your Davey product, we suggest in the first instance that you contact the Davey Dealer from which you purchased the Davey product. Alternatively you can phone our Customer Service line on 1300 367 866 in Australia, or 0800 654 333 in New Zealand, or send a written letter to Davey at the address listed below. On receipt of your claim, Davey will seek to resolve your difficulties or, if the product is faulty or defective, advise you on how to have your Davey product repaired, obtain a replacement or a refund.

Your Davey Two Year Guarantee naturally does not cover normal wear or tear, replacement of product consumables (i.e. mechanical seals, bearings or capacitors), loss or damage resulting from misuse or negligent handling, improper use for which the product was not designed or advertised, failure to properly follow the provided installation and operating instructions, failure to carry out maintenance, corrosive or abrasive water or other liquid, lightning or high voltage spikes, or unauthorized persons attempting repairs. Where applicable, your Davey product must only be connected to the voltage shown on the nameplate.

Your Davey Two Year Guarantee does not cover freight or any other costs incurred in making a claim. Please retain your receipt as proof of purchase; you **MUST** provide evidence of the date of original purchase when claiming under the Davey Two Year Guarantee.

Davey shall not be liable for any loss of profits or any consequential, indirect or special loss, damage or injury of any kind whatsoever arising directly or indirectly from Davey products. This limitation does not apply to any liability of Davey for failure to comply with a consumer guarantee applicable to your Davey product under the Australian or New Zealand legislation and does not affect any rights or remedies that may be available to you under the Australian or New Zealand Consumer Legislation.

In Australia, you are entitled to a replacement or refund for a major failure and for compensation for any other reasonably foreseeable loss or damage. You are also entitled to have the goods repaired or replaced if the goods fail to be of acceptable quality and the failure does not amount to a major failure.

Should your Davey product require repair or service after the guarantee period; contact your nearest Davey Dealer or phone the Davey Customer Service Centre on the number listed below.

For a complete list of Davey Dealers visit our website ([davey.com.au](http://davey.com.au)) or call:



### AUSTRALIA

**Customer Service Centre**  
6 Lakeview Drive,  
Scoresby, Australia 3179  
Ph: 1300 367 866  
Fax: 1300 369 119  
Website: [davey.com.au](http://davey.com.au)

### NEW ZEALAND

**Customer Service Centre**  
7 Rockridge Avenue,  
Penrose, Auckland 1061  
Ph: 0800 654 333  
Fax: 09 527 7654  
Website: [daveynz.co.nz](http://daveynz.co.nz)

Davey Water Products Pty Ltd  
Member of the GUD Group  
ABN 18 066 327 517

© Davey is a registered trade mark of Davey Water Products Pty Ltd.  
© Davey Water Products Pty Ltd 2011.

P/N 400595-5 supersedes P/N 400595-4

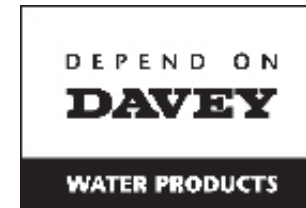

# Installation and Operating Instructions for Davey HM Series Pressure Systems with Pressure Switch

(Pressure Tank required and purchased separately)



**NOTE:** Prior to installation remove the red transport plugs & associated seals from the suction and/or discharge ports.



**WARNING:** The pump, pressure tank and associated pipework operate under pressure. Under no circumstances should the pump, pressure tank or associated pipework be disassembled unless the internal pressure of the unit has been relieved. Failure to observe this warning will expose persons to the possibility of personal injury and may also result in damage to the pump, pipework or other property.



**WARNING:** Failure to follow these instructions and comply with all applicable codes may cause serious bodily injury and/or property damage.

Please pass these instructions on to the operator of this equipment.

\* Installation and operating instructions are included with the product when purchased new. They may also be found on our website.

Prior to using this pump you must ensure that:

- The pump is installed in a safe and dry environment
- The pump enclosure has adequate drainage in the event of leakage
- Any transport plugs are removed
- The pipe-work is correctly sealed and supported
- The pump is primed correctly
- The power supply is correctly connected
- All steps have been taken for safe operation

Appropriate details for all of these items are contained in the following Installation and Operating Instructions. Read these in their entirety before switching on this pump. If you are uncertain as to any of these Installation and Operating Instructions please contact your Davey dealer or the appropriate Davey office as listed on the back of this document.

Congratulations on your purchase of a high quality, Australian built Davey pressure system. All components have been designed and manufactured to give trouble free, reliable operation.

**Before installing your new pump, please read all instructions carefully as failures caused by incorrect installation or operation are not covered by the guarantee. Your Davey pressure system is designed to handle clean water. The system should not be used for any other purpose without specific referral to Davey. The use of the system to pump flammable, corrosive and other materials of a hazardous nature is specifically excluded.**



**NOTE:** Prior to installation remove the red transport plugs from the suction and/or discharge.

1. Pressure Tank (purchase separately)
2. Pressure Switch
3. Discharge Outlet
4. Suction Inlet
5. Pump Body
6. Motor
7. Pressure Gauge
8. Priming Plug (pump)
9. Non-Return Valve (not illustrated, supplied loose)

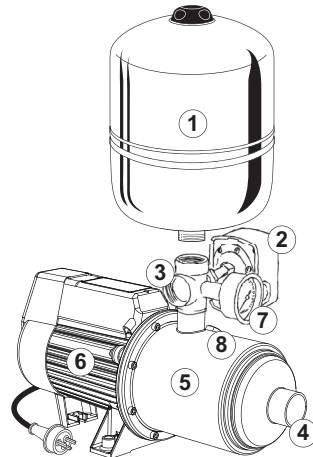



## Pressure Tank

Your Davey HM Series Pressure Pump requires the connection of a Hydro Pneumatic pressure vessel. This can be connected by screwing it directly on to the top of the discharge outlet or can be connected via a hose to the side of the discharge tee.

We recommend the Davey Supercell range of tanks.

 **NOTE:** For protection, the Davey® pump motor is fitted with an automatic “over temperature” cut-out. Constant tripping of this overload device indicates a problem e.g. low voltage at pump, excessive ambient temperature (above 50°C) in pump enclosure.

 **WARNING:** When servicing or attending pump, always ensure power is switched off and lead unplugged. Electrical connections should be serviced only by qualified persons. If the electrical supply lead of this pressure system is damaged, it must be replaced.

 Care should also be taken when servicing or disassembling pump to avoid possible injury from pressurised water. Unplug pump, relieve pressure by opening a tap on the discharge side of the pump and allow any hot water in the pump to cool before attempting to dismantle.

 During servicing, use only approved, non-petrochemical based oring and gasket lubrication. If unsure, consult your Davey Dealer for advice.

 **WARNING:** Do not use hydrocarbon based or hydrocarbon propelled sprays around the electrical components of this pump.

 **WARNING:** Automatic reset thermal overloads will allow the pump to restart without warning. **ALWAYS** disconnect the pump motor from the electrical supply before maintenance or repairs.

## Pressure Switch Setting and Tank Precharge

Your Davey HM Series Pressure Pump should have the correct pressure switch settings for zero suction lift. If your pump is installed with a suction lift you may need to have the cut out switch settings adjusted. The pressure tank(s) fitted must be air pre-charged as per the table in the maintenance section of these instructions.

## Choosing a Site

Choose a site with a firm base and as close to the water source as possible with correct power supply. Make sure your pressure system is always connected to an adequate, reliable source of clean water.

## Housing your Davey Pressure System

To protect your pressure system from the weather, make sure the pump house is both water proof, frost free and has adequate ventilation. The pump should be horizontally mounted on a firm base allowing for drainage, to avoid damage to flooring etc., that over time may occur from leaking pipe joints or pump seals. Do not mount the pump vertically. Never place flammable materials on or near your pump.

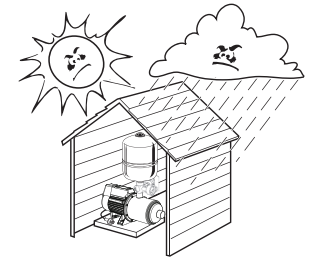



 **WARNING:** Some insects, such as small ants, find electrical devices attractive for various reasons. If your pump enclosure is susceptible to insect infestation you should implement a suitable pest control plan.

 **WARNING:** Do not use hydrocarbon based or hydrocarbon propelled sprays around the electrical components of this pump.

## Power Connection

Connect lead to power supply designated on pump label. Do not use long extension leads as they cause substantial voltage drop, poor pump performance and may cause motor overload.

 The electrical connections and checks must be made by a qualified electrician and comply with applicable local standards. Poor installation or poor power supply may even result in electrical fires!

 In accordance with AS 3350.2.41 we are obliged to inform you that this pump is not to be used by children or infirm persons and must not be used as a toy by children.

## Electrical Power Surge Protection

An electrical power surge or spike can travel on the supply lines and cause serious damage to your electrical equipment.

If the installation is subject to electrical power surges or lightning we strongly recommend the use of suitable additional surge protection devices on ALL electrical equipment.

In accordance with AS 3350.2.41 we are obliged to inform you that this pump is not to be used by children or infirm persons and must not be used as a toy by children.



**NOTE:** For protection, the Davey pump motors are fitted with an automatic reset thermal overload, constant tripping of this overload indicates a problem e.g. low voltage at pump, excessive temperature (above 50°C) in pump enclosure.

## Pipe Connections

For best performance use P.V.C. or polythene pipes at least the same diameter as the pump's inlet and delivery outlet openings. Larger diameter pipe may be used to minimise resistance to flow when pumping longer distances.

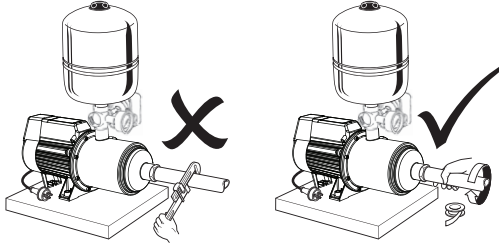

**Do not use pipe thread sealing compounds on any part of this pump. ONLY use Teflon sealing tape.**

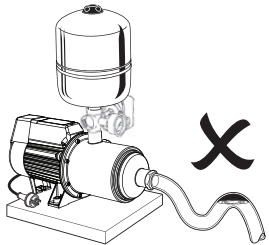

Use unions at pipe connections to enable easy removal and servicing. Use sufficient tape to ensure airtight seal and hand tighten only. To prevent strain on pump threads always support heavy inlet and outlet pipes. If there is a likelihood the water supply may contain solid particles such as pieces of plant or vegetable matter, a filter should be installed before the pump to avoid blocking of water ways. Lay suction pipe at a constant gradient to avoid air pockets which may reduce pump efficiency.



**NOTE:** Suction leaks are the largest cause of poor pump performance and are difficult to detect. Ensure all connections are completely sealed using thread tape only.

## Trouble Shooting Check List

- A) MOTOR RUNS WHEN SWITCHED ON BUT DOES NOT PUMP.**
1. Suction line and pump body not filled with water.
  2. Air leaks in suction lines or suction pipe not under water.
  3. Air trapped in suction lines (also possible with flooded suction due to uneven rise in piping; eliminate humps and hollows).
  4. No water at source or water level too low.
  5. Valve on suction line closed.
- B) PUMP SWITCHES ON AND OFF FREQUENTLY (CYCLING).**
1. Check that tank air pressure is correct.
  2. Leaking taps, float valves etc. Check plumbing.
  3. Leaking check valve/foot valve.
  4. Pressure Switch may require adjustment to cater for flooded suction installations – consult your Davey dealer for advice.
- C) MOTOR DOESN'T START WHEN SWITCHED ON**
1. Power not connected.
  2. Supply voltage too low.
  3. "Over temperature" cut out tripped.\*
  4. Motor not free to turn e.g. a jammed impeller.
  5. Internal motor fault.



**NOTE:** For protection, single phase Davey pump motors are fitted with an automatic "over temperature" cut-out. Constant tripping of this overload device indicates a problem e.g. Low voltage at pump, excessive temperature (above 50°C) in pump enclosure.



**WARNING:** When servicing or attending pump, always ensure power is switched off and lead unplugged. Electrical connections should be serviced only by qualified persons. If the electrical supply lead of this pressure system is damaged, it must only be replaced by authorised Davey service personnel as special tools are required.



Care should also be taken when servicing or disassembling pump to avoid possible injury from hot pressurised water. Unplug pump, relieve pressure by opening a tap on the discharge side of the pump and allow any hot water in the pump to cool before attempting to dismantle.

## Maintenance

The only regular attention your new pressure system requires is to check the pressure tank's air charge every 6 months. This can be checked at the air valve with a tyre gauge. Do not charge tank to a higher pressure than 14 kPa below cut-in pressure setting.

To check air pressure in tank:

1. Switch off pump.
2. Open outlet nearest to pump to release water pressure.
3. Remove air valve cap from top of Supercell tank and charge tank to correct pressure using air pump and check with tyre gauge.
4. Switch on.
5. Close outlet.

### NOTE:

Your pump is designed to operate as an automatic pressure system. The pressure tank will require a specific precharge air pressure dependent upon model.

While your pressure tank may have been precharged in manufacture, the precharge pressure should be checked upon installation and every 6 months thereafter. Follow the instructions on the tank. As a guide, the precharge settings are listed below:-

Pump Model	Pressure Settings		
	Cut Out kPa	Cut In kPa	Tank kPa
HM270-19P	300	200	180
HM60-06P			
HM90-08P	400	250	230
HM160-15P			
HM270-25P			
HM60-08P			
HM90-11P	500	300	280
HM160-19P			
HM60-10P	620	350	330
HM90-13P			



Note: The above are standard settings which may be adjusted according to site conditions. Any adjustments should only be made by a suitably qualified and experienced person.



**DO NOT USE THREAD SEALING COMPOUNDS, HEMP OR PIPE DOPE!**

## Where to use Check Valves and Foot Valves

A check valve is required for fitting to installations with flooded or positive suction. Care should be taken to ensure that it is correctly installed in the suction line for installations with flooded or positive suction. Installations with flooded suction require a gate valve so water supply can be turned off for pump removal and servicing. On installations with a suction lift a good quality foot valve with strainer is required.

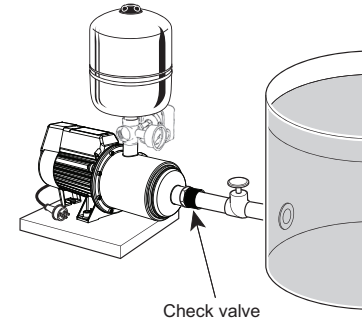
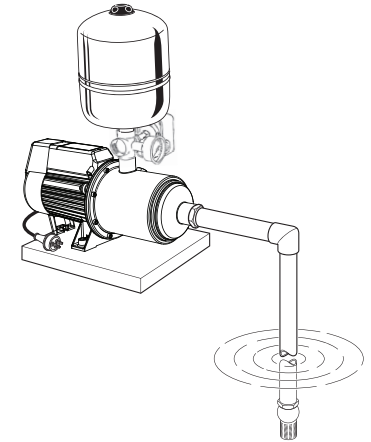

Check valve

Installations with flooded suction require a gate or isolating valve so water supply can be turned off for pump removal and servicing.



### Abrasive Materials

The pumping of abrasive materials will cause damage to the pressure system which will then not be covered by the guarantee.

## For Automatic Pressure Pumps Installed with a Mains Pressure Hot Water System

To protect your system from damage caused by back pressure from hot water systems. You should always have installed on the hot water inlet an approved non-return valve.

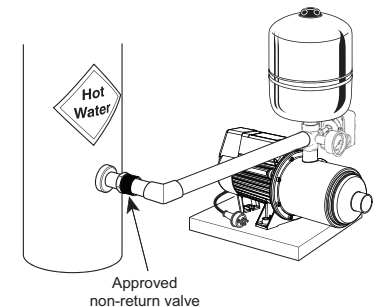

Approved non-return valve



**NOTE: Always ensure hot water systems are installed in compliance with manufacturers recommendations and in accordance with all local regulations.**

## Connection of Mains Scheme or Town Water Supply to either Suction or Discharge of Pumps & Pressure Systems

Most Water Supply Authorities have strict regulations regarding direct connection of pumps to mains water supplies. In most cases an isolating tank is required between mains supply and pump. Davey also recommend this method. Directly applied mains pressure can exceed pump operating pressure and damage pump.

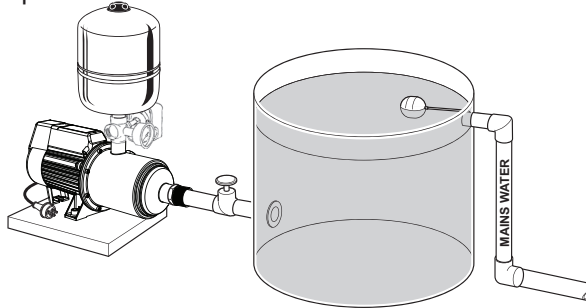

Davey Water Products Pty Ltd can not accept responsibility for loss or damage resulting from incorrect or unauthorised installations.

## Priming and Operation



**WARNING:** When servicing or attending pump, always ensure power is switched off and lead unplugged. Electrical connections should be serviced only by qualified persons. If the electrical supply lead of this pressure system is damaged, it must be replaced.

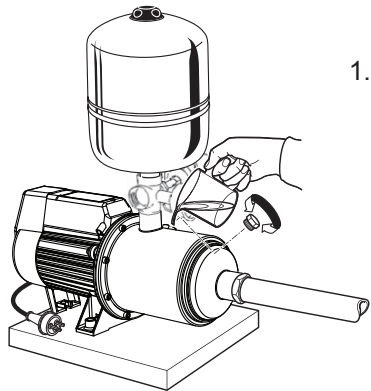

1. Remove priming plug and fill casing and suction line (on flooded suction, simply open gate valve to pump). When full, replace priming plug.



2. Ensure outlet nearest to pump is open.

3. Ensure all valves in suction line are open and plug into electrical supply.

4. Switch on power and the pump will run. A full flow of water should be discharged from the open tap. Allow water to flow for 10-20 seconds, or at least until all air has been expelled from the pump and then close the outlet.

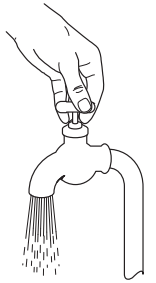

5. If the pump stops pumping (no water flow), with the tap open, stop the pump and repeat from Step 1 onwards.

If the pump motor stops with the tap open see troubleshooting checklist.

6. Close the open outlet or tap and the pump should stop after a few seconds. If not, stop the pump and repeat from Step 1 onwards or consult the troubleshooting checklist.