

## Davey® Repair or Replacement Guarantee

In the unlikely event in Australia or New Zealand that this Davey product develops any malfunction within warranty periods beginning from the date of original purchase due to faulty materials or manufacture, Davey will at our option repair or replace it for you free of charge, subject to the conditions below.

### Davey Guarantee Period

Firefighter Liquid End - One Year

Engines fitted to Davey pumps are the responsibility of the engine manufacturer or their representative. The manufacturer's stated guarantee terms and conditions are contained in the owners / operators manual provided with this pump.

Should you experience any difficulties with your Davey product, we suggest in the first instance that you contact the Davey Dealer from which you purchased the Davey product. Alternatively you can phone our Customer Service line on 1300 367 866 in Australia, or 0800 654 333 in New Zealand, or send a written letter to Davey at the address listed below. On receipt of your claim, Davey will seek to resolve your difficulties or, if the product is faulty or defective, advise you on how to have your Davey product repaired, obtain a replacement or a refund.

Your Davey Guarantee naturally does not cover normal wear or tear, replacement of product consumables (i.e. mechanical seals, bearings or capacitors), loss or damage resulting from misuse or negligent handling, improper use for which the product was not designed or advertised, failure to properly follow the provided installation and operating instructions, failure to carry out maintenance, corrosive or abrasive water or other liquid, lightning or high voltage spikes, or unauthorized persons attempting repairs. Where applicable, your Davey product must only be connected to the voltage shown on the nameplate.

Your Davey Guarantee does not cover freight or any other costs incurred in making a claim. Please retain your receipt as proof of purchase; you **MUST** provide evidence of the date of original purchase when claiming under the Davey Guarantee.

Davey shall not be liable for any loss of profits or any consequential, indirect or special loss, damage or injury of any kind whatsoever arising directly or indirectly from Davey products. This limitation does not apply to any liability of Davey for failure to comply with a consumer guarantee applicable to your Davey product under the Australian or New Zealand legislation and does not affect any rights or remedies that may be available to you under the Australian or New Zealand Consumer Legislation.

In Australia, you are entitled to a replacement or refund for a major failure and for compensation for any other reasonably foreseeable loss or damage. You are also entitled to have the goods repaired or replaced if the goods fail to be of acceptable quality and the failure does not amount to a major failure.

Should your Davey product require repair or service after the guarantee period; contact your nearest Davey Dealer or phone the Davey Customer Service Centre on the number listed below.

For a complete list of Davey Dealers visit our website ([davey.com.au](http://davey.com.au)) or call:



#### AUSTRALIA

**Customer Service Centre**  
6 Lakeview Drive,  
Scoresby, Australia 3179  
Ph: 1300 367 866  
Fax: 1300 369 119  
Website: [davey.com.au](http://davey.com.au)

#### NEW ZEALAND

**Customer Service Centre**  
7 Rockridge Avenue,  
Penrose, Auckland 1061  
Ph: 0800 654 333  
Fax: 09 527 7654  
Website: [daveynz.co.nz](http://daveynz.co.nz)

Davey Water Products Pty Ltd  
Member of the GUD Group  
ABN 18 066 327 517

© Davey & Firefighter are registered trade marks of Davey Water Products Pty Ltd.  
© Davey Water Products Pty Ltd 2011.

P/N 49367-6 supersedes P/N 49367-5

\* Installation and operating instructions are included with the product when purchased new. They may also be found on our website.

# PORTABLE SELF PRIMING PUMPS

DEPEND ON  
**DAVEY**

WATER PRODUCTS

## INSTALLATION AND OPERATING INSTRUCTIONS



**These Instructions and the accompanying engine manufacturer's instructions must be delivered with the pump to the operator.**



#### NOTE:

- Your Davey pump is fitted with a four stroke engine WHICH **REQUIRES OIL IN THE SUMP.**
- Petrol engines require **UNLEADED** petrol in the fuel tank.
- Read **ALL** instructions to avoid equipment failure which may not be covered by guarantee.
- Fill sump with oil and pump with water before starting. **YANMAR** diesel engines do not have low oil protection. Check oil levels and maintain oil quality regularly.

**Engine:** Fill sump with oil to correct level before starting the four stroke engine. Operation at high altitudes, high temperatures and/or humidity will reduce engine performance.



#### IMPORTANT NOTICE:

**The Honda and Briggs & Stratton engines fitted to Davey Firefighters® have an automatic oil level cut-out which will stop the engine and/or prevent starting when oil level is low and/or when engine is tilted.**

**IN EMERGENCY CIRCUMSTANCES ONLY, OIL LEVEL CUT-OUT MAY BE DISABLED AS FOLLOWS:**

**FOR HONDA:** Disconnect yellow lead to starting switch at 'bullet' junction.  
**FOR BRIGGS & STRATTON:** Remove lead from 'oil guard' sensor. In Vanguard models this should be done at the sensor light. In INTEK models this should be done at the sensor plug, which is located in the crankcase cover.

**NOTE: WARRANTY FROM THE ENGINE MANUFACTURERS MAY BE JEOPARDISED BY SUCH ACTIONS.**

## READ ALL INSTRUCTIONS BEFORE OPERATING PUMP



**WARNING:** Engine manufacturer's instructions must be followed to ensure safe operation of this product and to avoid possible engine damage or reduced engine life.



In accordance with AS 3350.2.41 we are obliged to inform you that this pump is not to be used by children or infirm persons and must not be used as a toy by children.

### PUMP LOCATION:

For most efficient operation, site the pump as close to the water as practical. It is essential for the correct function of the engine that it be located on a horizontal surface. If allowed to run at an inclination, the oil lubrication system of the engine may not operate correctly. Subsequent engine failure would not be covered by the manufacturer's guarantee.

The pump should be positioned in a well drained location to avoid possible property damage by leaking hose fittings or pump seals, spilled engine fuel etc. If you intend to operate your pump on a hard surface, Davey suggest a suitable resilient mounting to be fitted to your pump and engine.

### SUCTION PIPE:

A reinforced or non-collapsible hose should be used for the pump suction. The minimum suction pipe size should be 38mm (1 1/2") I.D. for up to 6.5hp Firefighter® models, 50mm (2") I.D. for G5006 and 9hp & 13hp Firefighter® models and 80mm (3") I.D. for G8016 Firefighter® models. A strainer should always be fitted to the bottom of the suction pipe. The strainer should be kept out of sand, mud etc., to avoid particles being drawn into the pump and causing damage by abrasion.

Always locate the pump so that the rise of suction pipe from water to pump is even with no humps or hollows where air may be trapped. All pipe connections must be air tight for best priming and operation - check that washers in nuts and tails are in good order.

### DELIVERY PIPE:

Care should be taken on correct selection of pipe pressure rating as single stage Firefighter® units are capable of delivering pressures up to 650kPa (93psi). Two stage Firefighter® Plus units are capable of pressures up to 1135kPa (165psi).

### PUMP PRIMING:

The priming plug and drain plug both have "bayonet" style fitment, with a safety release mechanism. To insert the plug, ensure the handles on the plug are in line with the engine shaft or pointing towards the engine for the priming plug (figure one) and vertical for the drain plug.

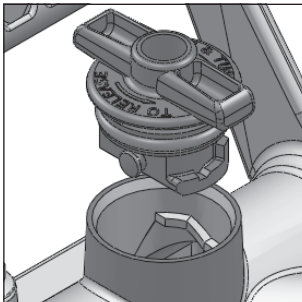

Figure 1

### PUMP AND PIPEWORK

- Run the pump every week or so during the fire season to ensure it and associated pipework etc is in good working order. This will also help turnover the fuel and make sure the lubricating oil is circulated around the engine.
- Ensure the water source is free of leaves and sticks etc which may block inlet strainers and obstruct the water flow to the pump.
- Check for pipe leaks and the correct operation of all valves connecting the pump to the water source and to the discharges.
- Air leaks on the suction line are the number one cause of pump problems, make sure all rubber gaskets and seals are in good order.

### BE PREPARED!

Your pump and pipework is an important part of fire protection, but so are the other things you must do to be ready.

Davey strongly encourage you to work through your fire plan and make sure it's able to work under a realistic assessment of the worst possible situation. Fire only really understands the worst possible situation.

### SPECIAL MODELS – Viton Seal Equipped

These special models, identified by a black handle (when factory fitted) or a sticker (when fitted in the field), have been supplied with Viton® seals and elastomers. This is to provide the pump with superior resistance to common agricultural chemicals. These pumps should still be flushed out with clean water after use.

### STORAGE OF UNIT:

The pump unit should be drained of water and normal engine storage procedure should be followed. (Run unit until fuel is exhausted, drain and fill sump with fresh oil). The unit should be stored in a dry place. Before starting pump after storage it should be checked to make sure that it is free to rotate by pulling Engine Starter with ignition off.

### REMOVAL OF IMPELLER:

Pump impeller is screwed clockwise onto the engine shaft. The impeller assembly is fixed together by a setscrew and can be disassembled in two halves by removing the setscrew or the entire impeller assembly can be removed.

To remove the entire impeller assembly, unscrew locking setscrew or impeller/s anti-clockwise using a socket in eye of impeller. If difficult to remove, lock engine crankshaft at recoil starter end.



**WARNING:** In the event of fire damage to the Viton® elastomers ("rubber"), consult your Davey dealer regarding safe handling of burnt Viton® components. Burnt Viton® emits a dangerous acid, which can cause serious health effects.



**NOTE:** The pump body should always be full of water when operating, and must not be allowed to run dry for extended periods. Check that there is flow through pump at all times when running as insufficient flow can cause damage not covered by guarantee.



**WARNING:** Pump may contain hot liquid under pressure.

Diesel engines require specific oils designed for diesel, and the diesel engine on your pump will need a different oil to that used for truck or motor vehicle engines.

Honda, Briggs & Stratton and Yanmar all offer their own branded specialty oils to suit their engines best, but no matter who makes the oil, use the right grades and stick to trusted brands.

Davey include a label with every engine to advise of the correct oil to use, which are:

- **Honda:** SAE 10W-30 mineral oil. For extreme conditions alternate oil grade may be appropriate – check manual.
- **Briggs and Stratton:** SAE 30 mineral oil. For extreme conditions alternate oil grade may be appropriate – check manual.
- **Yanmar:** MONOGRADE SAE 30, API- CC or CD mineral oil. For extreme temperatures SAE 40 may be necessary.

Running the engine regularly will help ensure the oil is distributed around the engine, thus providing the best lubrication and longer engine life.

### AIR CLEANERS

In a fire emergency you need every ounce of performance from your pump unit to be available, and poorly maintained air cleaners won't help you. Adequate clean air flowing into the engine at the right speed and temperature is vital for efficient combustion:

- Follow the engine manufacturers' schedule and instructions for the correct maintenance of the air cleaner.
- Ensure your engine has access to ample clean fresh air.
- Be careful changing the air cleaner from the engine manufacturers original equipment as these are specially designed for each engine

### ENGINE COOLING

The temperature at which an engine operates has a dramatic effect on the power it can deliver – the higher the ambient or surrounding heat and the more radiant heat the engine is exposed to the lower the performance.

The effects of radiant heat should not be underestimated:

1. Protect the engine from radiant heat: Install the engine in a flame proof enclosure which has some degree of insulating characteristic. Materials such as fibre cement sheeting, autoclaved aerated concrete or even concrete bricks provide good fire resistance and thermal insulation. Any enclosure must allow for adequate flow of clean air, while at the same time protecting the pump unit from radiant heat. Make sure the exhaust is correctly routed out of the enclosure.
2. Add a mist spray or sprays around the pump enclosure to both protect the area from embers, but also to aid cooling.
3. Make sure the enclosure is easily accessible for engine fuelling and pump servicing

### GENERAL ENGINE MAINTENANCE

Sometimes it's the little things that lead to problems, but they are often easy to see if you know what to look for:

**Fuel lines:** Check to ensure there is no water in the carburettor bowl. Make sure any fuel lines have not degraded over time.

**Recoil starters:** Ensure they work smoothly. Check the recoil rope for any signs of wear, if uncertain, replace them.

**Service schedules:** Small engines are often not treated as well as they deserve, oil changes are the most common item neglected.

Insert the plug (figure 2) and then turn 1/4 clockwise (figure 3).

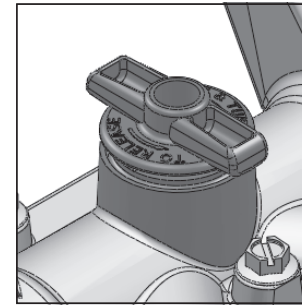

Figure 2

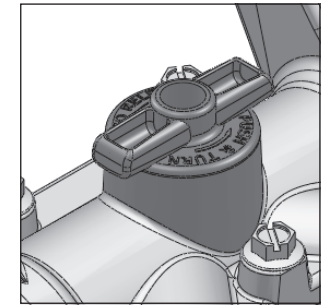

Figure 3

Once the pump is pressurised the plug will pop up slightly engaging the security latch (figure 4), thus preventing accidental removal. While the plugs can be removed under pressure, the operator must intentionally push the plug in and then, whilst still holding the plug in, twist counter-clockwise on the plug. It is possible to abort plug removal part way through the process.

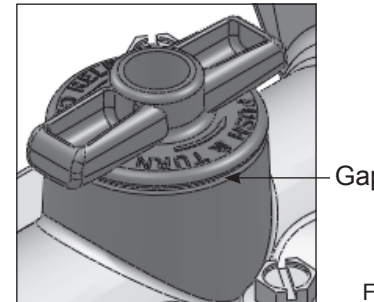

Figure 4



Figure 5

The drain plug fitment is similar to the priming plug. However, to insert the drain plug the plug handles start in the vertical position.

Keep the plug and it's surround free from sand and grit. Occasionally apply a suitable silicon based rubber grease (petroleum based greases are not acceptable) to the oring.

The pump drain plug is identical in operation. Both plugs are available with a 1/4" BSP tapping to facilitate the fitment of pressure gauges or automatic drain valves etc.

The three keys steps to priming your Firefighter® pump are to:

1. Have an air tight suction line. This is critical even for self priming pumps.
2. Fill the pump casing, fully with water before starting the engine.
3. Run the pump at full speed to evacuate the air from the suction line and the pump housing.

Steps 1 & 3 is where mistakes are commonly made.

Failure to correctly establish prime can result in unsatisfactory pump performance, and in some cases the pump will run in a closed (or dead) head circumstance. Closed head operation can result in the remaining water in the pump being heated to dangerously high temperatures.



**CAUTION: If a pump has been allowed to run at closed (or dead) head, do not open any valves of priming plugs until the pump casing has cooled!**

**Air Tight Suction:** In permanent installations this is something usually achieved once and forgotten about. The use of correctly applied thread tape is usually the key. In portable pumps, it is something more frequently encountered, so attention to some simple rules will make it easier to achieve:

1. Always keep rubber gaskets in good condition, especially important on hose tails and quick connector.
2. Where gaskets have to seal on the face of the inlet, ensure the mounting face is flat and not damaged.
3. Make sure suction hoses do not have holes or splits; just because water does not escape from the hole does not mean it won't allow air into the hose when priming.

**Evacuate the Air:** Even the most powerful pump will experience problems trying to evacuate the air from itself and its suction line if it has nowhere for the air to go. To help clear the air and properly prime the pump:

1. Make sure the pump has an open discharge to atmosphere nearby to allow the evacuation of the air. Use one of the outlets equipped with a ball valve if possible.
2. Isolate the rest of the discharge pipework until the pump is properly primed. This is especially important in self priming installations where the pump may regularly be needed to pump water through a long discharge line. Once it is clear the pump has established prime the outlet to atmosphere can be shut and the major discharge line opened. **Note:** Failure to isolate the major discharge line during priming may result in a "false" prime or failure to prime at all. This may result in closed head operations – see above notes.
3. For engine driven self priming pumps, it is very important to run the pump at full speed during the priming operation. Failure to run at full speed may result in failure to prime etc.

Allow up to 3 minutes for long or deep suction.

If the pump fails to prime, then it may be due to the pump flap valve not seating properly, an air leak in the suction pipe or fittings, a blocked suction pipe air locking (as above), or the bottom end of the pipe embedded in mud.



**NOTE: When transporting your Davey Portable Self Priming Pump, water from the casing may leak back past the priming flap. Before attempting to self prime the pump you may need to check that the pump casing is full of water.**

#### **PUMP OPERATION:**

High performance can be obtained from these pumps if the engine speed is increased, however, we do not recommend the pumps be operated over 3600rpm for extended periods, as this may overload the engine and reduce its working life. Operating the engine at full throttle for extended periods will shorten engine life and may result in premature failure. For operations such as irrigation or dam and tank filling, the throttle should be closed to around 3/4 maximum. This should correspond to around 3000rpm maximum.

#### **AVOIDING PUMP DAMAGE:**

Pumping water containing sand, dirt or other abrasive materials will result in accelerated pump wear and seal failure. Damage of this kind is not covered by guarantee.

Pumping water containing chemicals or high concentrations of salt may damage pump components. If the pump is used for this kind of service, life will be extended by always washing thoroughly with clean water after use. However, Davey cannot accept responsibility for damage caused by chemicals, salt or corrosive fluids.

Pumping hydrocarbon based liquids, even in diluted form, is likely to cause damage to internal pump components and such failure is not covered by guarantee.

Davey ensure their pumps and the engines they fit to them are matched, and this is confirmed by engine manufacturers by programs such as the Honda's engine matching test and approvals program.

#### **BE PREPARED!**

Even with the best equipment though, other things need to be considered at the start of every fire season to ensure the pump unit and associated equipment is ready if needed. Here's a checklist for your pump and equipment.

#### **PRACTICE**

Simply having the best golf clubs does not guarantee outstanding performance around the links. The same rules apply to you fire plan:

Make sure you and all your team are competent in the use of the equipment:

- Can they start and correctly operate your pump unit?
- Can they operate the hoses correctly?
- Do they have a clear understanding of risks and what to do to ensure safety?

Run drills; practice and make sure everyone understand the fire plan and their part in that plan.

#### **FUEL - PETROL**

Modern petrol engines very seldom actually have starting or running problems due to fuel vaporising, the usual fuel related problem is due to old fuel.

Most people are unaware that petrol has a limited life, it loses its volatility or quite simply it goes "stale". This may mean that if you have a petrol driven pump unit fully fuelled and ready to go in September, by December it may not start. There are some important procedures to follow to ensure your petrol engine is ready to start and operate correctly:

- Change your fuel every two months: While in perfect conditions the shelf life should be at least three months, are you prepared to take the chance? Changing the fuel over can be by usage or by draining the fuel from the engine. It also applies to fuel you have stored, even in approved containers.
- Use a fuel stabiliser to extend the storage life of the fuel: Both Honda and Briggs & Stratton offer fuel additives or stabilisers which dramatically extend the shelf life of petrol. These additives must be added at the time of purchase of the fuel, and they will work on two stroke fuel as well. They will NOT renew already stale fuel.

#### **FUEL – DIESEL**

While diesel fuel has a longer shelf life, it is still limited, contrary to some miss beliefs. BP Australia recommends that:

Under normal storage conditions diesel fuel can be expected to stay in a useable condition for:

- 12 months or longer at an ambient of 20°C.
- 6-12 months at an ambient temperature higher than 30°C.

Keeping stored diesel fuel at lower temperatures in containers free of air and water, and out of contact with zinc or copper (or alloys including them) can help extend the storage time. The main problem is the settling of sediments and gums, which in the case of small diesel engines can be a very serious issue and can do major harm to the engine.

Another very important thing to remember with diesel fuel is cleanliness, dirt in the fuel can do serious damage to the fuel injection pumps, and in prolonged situations can lead to complete engine failure. Correct fuel filtration on the engine's fuel tank is absolutely critical.

For more information on keeping your diesel fuel longer refer to the following BP website: [http://www.bp.com/liveassets/bp\\_internet/australia/corporate\\_australia/STAGING/local\\_assets/downloads\\_pdfs/f/Long\\_Term\\_Storage\\_ADF.pdf](http://www.bp.com/liveassets/bp_internet/australia/corporate_australia/STAGING/local_assets/downloads_pdfs/f/Long_Term_Storage_ADF.pdf)

#### **ENGINE OIL**

The use of good quality, correctly rated engine oil is very important to the long term dependability of your engine, especially when you need it most. Check the manufacturer's recommendations for the correct grade of oil and stick to their recommendations. Do not use a synthetic, multigrade motor vehicle oil in your small engine, it simply is the wrong oil for this type of engine.